

# Service Manual

**Canon BW**

**Multi-PDL Printer Kit-F1**

**Canon**

Jan 5 2005



## Application

This manual has been issued by Canon Inc. for qualified persons to learn technical theory, installation, maintenance, and repair of products. This manual covers all localities where the products are sold. For this reason, there may be information in this manual that does not apply to your locality.

## Corrections

This manual may contain technical inaccuracies or typographical errors due to improvements or changes in products. When changes occur in applicable products or in the contents of this manual, Canon will release technical information as the need arises. In the event of major changes in the contents of this manual over a long or short period, Canon will issue a new edition of this manual.

The following paragraph does not apply to any countries where such provisions are inconsistent with local law.

## Trademarks

The product names and company names used in this manual are the registered trademarks of the individual companies.

## Copyright

This manual is copyrighted with all rights reserved. Under the copyright laws, this manual may not be copied, reproduced or translated into another language, in whole or in part, without the written consent of Canon Inc.

***COPYRIGHT © 2001 CANON INC.***

*Printed in Japan*

## Caution









Use of this manual should be strictly supervised to avoid disclosure of confidential information.

---

## Symbols Used



---

This documentation uses the following symbols to indicate special information:

Symbol	Description
	Indicates an item of a non-specific nature, possibly classified as Note, Caution, or Warning.
	Indicates an item requiring care to avoid electric shocks.
	Indicates an item requiring care to avoid combustion (fire).
	Indicates an item prohibiting disassembly to avoid electric shocks or problems.
	Indicates an item requiring disconnection of the power plug from the electric outlet.
 Memo	Indicates an item intended to provide notes assisting the understanding of the topic in question.
 REF.	Indicates an item of reference assisting the understanding of the topic in question.
	Provides a description of a service mode.
	Provides a description of the nature of an error indication.

The following rules apply throughout this Service Manual:

1. Each chapter contains sections explaining the purpose of specific functions and the relationship between electrical and mechanical systems with reference to the timing of operation.

In the diagrams,  represents the path of mechanical drive; where a signal name accompanies the symbol, the arrow  indicates the direction of the electric signal.

The expression "turn on the power" means flipping on the power switch, closing the front door, and closing the delivery unit door, which results in supplying the machine with power.

2. In the digital circuits, '1' is used to indicate that the voltage level of a given signal is "High", while '0' is used to indicate "Low". (The voltage value, however, differs from circuit to circuit.) In addition, the asterisk (\*) as in "DRMD\*" indicates that the DRMD signal goes on when '0'.

In practically all cases, the internal mechanisms of a microprocessor cannot be checked in the field. Therefore, the operations of the microprocessors used in the machines are not discussed: they are explained in terms of from sensors to the input of the DC controller PCB and from the output of the DC controller PCB to the loads.

The descriptions in this Service Manual are subject to change without notice for product improvement or other purposes, and major changes will be communicated in the form of Service Information bulletins.

All service persons are expected to have a good understanding of the contents of this Service Manual and all relevant Service Information bulletins and be able to identify and isolate faults in the machine."



# Contents

## Chapter 1 Specifications

1.1 Product composition .....	1- 1
1.1.1 Product Composition .....	1- 1
1.2 Specifications .....	1- 2
1.2.1 Specifications .....	1- 2
1.2.2 PCL Printer Driver .....	1- 3
1.2.3 PS Printer Driver .....	1- 4

## Chapter 2 Functions

2.1 New Function .....	2- 1
2.1.1 Canon Driver Information Assist Service (DIAS) .....	2- 1
2.1.2 FTP Printing .....	2- 2
2.1.3 Halftone Settings .....	2- 4
2.1.4 Secured Print Jobs .....	2- 5
2.1.5 Up to 50 mm of Gutter .....	2- 8
2.1.6 Processing on System .....	2- 9

## Chapter 3 Installation

3.1 Checking components .....	3- 1
3.1.1 Checking the Contents .....	3- 1
3.2 Installation procedure .....	3- 2
3.2.1 Installation .....	3- 2





---

# Chapter 1 Specifications

---



# Contents

1.1 Product composition.....	1-1
1.1.1 Product Composition .....	1-1
1.2 Specifications .....	1-2
1.2.1 Specifications .....	1-2
1.2.2 PCL Printer Driver .....	1-3
1.2.3 PS Printer Driver .....	1-4



# 1.1 Product composition

## 1.1.1 Product Composition

0008-9164

Multi-PDL Printer Kit-F1 EUR/OTH

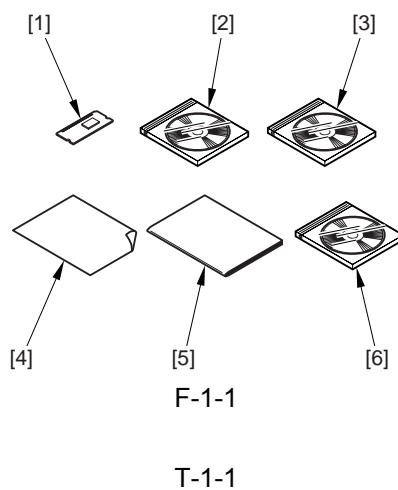

[1]	Boot ROM (N type)	1 pc.
[2]	User software CD-ROM unit (English, French, German, Italian, Spanish)	1 pc.
[3]	N/W ScanGear CD-ROM (English, French, German, Italian, Spanish)	1 pc.
[4]	Release note (English, French, German, Italian, Spanish)	1 pc.
[5]	N/W Quick Start Guide (English, French, German, Italian, Spanish)	1 pc.
[6]	User Manual CD-ROM (English, French, German, Italian, Spanish)	1 pc.

## 1.2 Specifications

### 1.2.1 Specifications

0008-9165

The main specifications and features of the kit are as shown below.

<Characteristics>

- printing is virtually immediate
- output is close to screen display

T-1-2

Specifications		
Data processing resolution		600 dpi
Effective print area	PCL	main scanning direction: 1/6 inch
		sub scanning direction: 1/6 inch
	PS3	main scanning direction: 4.5mm
		sub scanning direction: 4.5mm
Supported operating systems		Windows 2000 Professional/Server/ Advanced Server
		Windows XP Home Edition/Professional
		Windows Server 2003 Standard Edition/ Enterprise Edition
		Windows 98/98SE/ME
		Windows NT4.0 Workstation/Server
Paper size		default papers

#### Non-default paper

T-1-3

User-defined paper		
PCL	minimum	91.53 mm × 139.53 mm
	maximum	288.53 mm × 423.53 mm

User-defined paper		
PS3	minimum	91.00 mm × 139.00 mm
	maximum	288.00 mm × 423.00 mm
<p>Note:</p> <p>The value in parentheses indicates the area in mm<sup>2</sup>.</p> <p>- The height and width can be specified by 1/10 mm(Except US)or 1/100 inch(US).</p> <p>- The height must be equal to or greater than width.</p>		

## 1.2.2 PCL Printer Driver

0008-9166

### FONT HANDLING:

#### • PCL5e/5c

##### HP-GL/2 Mode

Texts are handled in the PCL mode, or in the HP-GL/2 mode if:

1. Characters are clipped.
2. Characters are rotated.

Supported typefaces include:

1. Standard
2. Italic
3. Bold
4. Bold Italic

##### Raster Mode

Use of a device font is determined by the driver setting.

If a device font is used, the Raster Mode will handle data the same as the HP-GL/2 Mode.

If not, the following restrictions will be imposed.

\*GDI Raster Fonts unavailable 1 byte fonts such as Courier, MS Sans Serif, MS Serif, etc.

\*GDI Vector Fonts available 1 byte fonts such as Modern, Roman, Script, etc.

\*TrueType Fonts available 1 byte fonts such as Arial, Courier New, Symbol, Times New Roman, etc.

#### • PCL6

PCL6 controls the texts if:

1. Characters are enlarged or reduced.

- 2.Characters are rotated.
- 3.Characters are clipped.

NOTE:

GDI Vector Fonts and TrueType Fonts become available only after added to Windows.

### 1.2.3 PS Printer Driver

0008-9167

**Target Printer:**

Apple LaserWriter8500 for command

OKI MICROLINE800PS2LT for print quality

**Target PDL:**

Adobe PostScript Level3 3011

Note. Omit advanced feature of RedBook.

**FONT HANDLING:**

**PS3**

PostScript PDL boards support the following font types.

-Type 0, 1, 2, 3, 4, 5, 6, 9, 10, 11, 14, 32 and 42

-CIDFontType 0, 1, 2 and 4



---

# Chapter 2    Functions

---



# Contents

2.1 New Function .....	2-1
2.1.1 Canon Driver Information Assist Service (DIAS) .....	2-1
2.1.2 FTP Printing .....	2-2
2.1.3 Halftone Settings .....	2-4
2.1.4 Secured Print Jobs .....	2-5
2.1.5 Up to 50 mm of Gutter .....	2-8
2.1.6 Processing on System.....	2-9



---

## 2.1 New Function

---

### 2.1.1 Canon Driver Information Assist Service (DIAS)

0008-5246

This is a subset version of the Netspot Suite Service, supporting Driver only: we have selected Driver's functions (mainly, the functions to acquire Device configuration information) and redesigned them. The DIAS has the following functions:

- To acquire Device configuration information (acquisition when setting up Printer Property.)
- To acquire calibration information (acquisition when setting up Printer Property and printing by the color LBP, Color iR, and etc.)
- To make recognition in department-control printing (communication when setting up Printer Property or when making a department-control print)

#### **Main structure of DIAS**

DIAS (DLL): It is a module loaded on Driver

DIAS (Service): It does a service of installation on printer server when using a shared printer (resident process)

CBT: It is a module group to control a local port, such as Centronics Cable or USB

H-VDC: It is a module group which are needed for the driver function in DIAS.

#### **Characteristics of DIAS**

- Local printer can acquire the configuration information in DIAS (DLL) only.

Local printer means a printer that is "Peer to Peer" connected with Local PC via LPR/IPP/Centronics Cable/USB and that Spooler (Print queue) appears on the Local PC.

- Shared printer needs to have DIAS (Service) installed on printer server.

The installation of DIAS (Service) must be done via Driver installer.

Shared printer means a printer whose Spooler (Print queue) appears on the printer server (Remote PC).

- However, in some cases, DIAS (Service) needs to be installed for Local Port connection. (See "Help" > "Troubleshoot the acquisition of configuration information".

1, WinNT4.0 OS Family (All)/ At the time of Local Port connection (LPT)

2, Win2k Server OS Family (Except Professional)/At the time of Local Port connection (LPT/USB) and Terminal Service introduction

3, WinXP Home/Professional Edition/ServerOS 2003 Family (X86:All)/ At the time of Local Port connection (LPT/USB) and Terminal Service introduction

#### **About the version indication**

The same Driver version indication as the one via Netspot Suite Service appears only when communicating with Device via DIAS (Service) (i.e., when connected through a shared printer).

### **Compatibility of DIAS and Netspot Suite Service**

DIAS and Netspot Suite Service are compatible and independent. Driver supporting DIAS does not use Netspot Suite Service even if it is installed.

### **Cautions when using DIAS**

CBT controls all access to Local Port; both DIAS (DLL/Service) and NetSpot Suite Service use CBT to access Local Port from the same PC.

CBT was installed only on Netspot Suite Service before; it is automatically uninstalled in response to uninstalling the existing NetSpot Suite Service. Follow the procedures below when uninstalling the former versions of NetSpot Suite Service v3.40 and when uninstalling JobMonitor v4.20 and former.

- Reinstall DIAS after the uninstallation is complete. (Reinstallation of DIAS is enabled via Installer.)
- Update NetSpot Suite Service to the latest version (v3.40 and later).

Former versions of NetSpot Suite Service v3.40

PS Printer Driver v2.10 and former

PCL5e Printer Driver v6.11 and former

PCL5c Printer Driver v6.11 and former

PCL6 Printer Driver v6.11 and former

UFR Printer Driver v1.10 and former

JobMonitor v4.10 and former

### **About a file name of the CBT module**

Following files are installed in the 'c:\Windows\system' folder. (For Windows XP/Windows 2000/NT/Server2003, this folder name is to be '%SystemRoot%\system32'.)

AuPort.exe

NBCBTNT.dll / NBCBT95.dll

NBPORTNT.exe / NBPORT95.exe

NBLOCALT.dll

nbcbspt.dat

### **Method of confirming when CBT is deleted**

The following message is displayed.

"Failed to obtain device information Make sure no printer error occurred and printout port setting is correct."

## **2.1.2 FTP Printing**

0008-5247

This device provides a FTP server for receiving print data. The device can accept print jobs sent in FTP from client PCs. This is called FTP printing, a new feature first employed on iRC 6800. To use this feature, the FTP Print option must be selected. It is selected by default. You can access the option by pressing Ad Func, System Settings, Network Settings, TCP/IP Settings, and FTP Print Settings buttons. In FTP Print Settings screen, only one pair of a user name and password can be entered for the user who can log in to the FTP server. No settings are made for both of the fields by default.

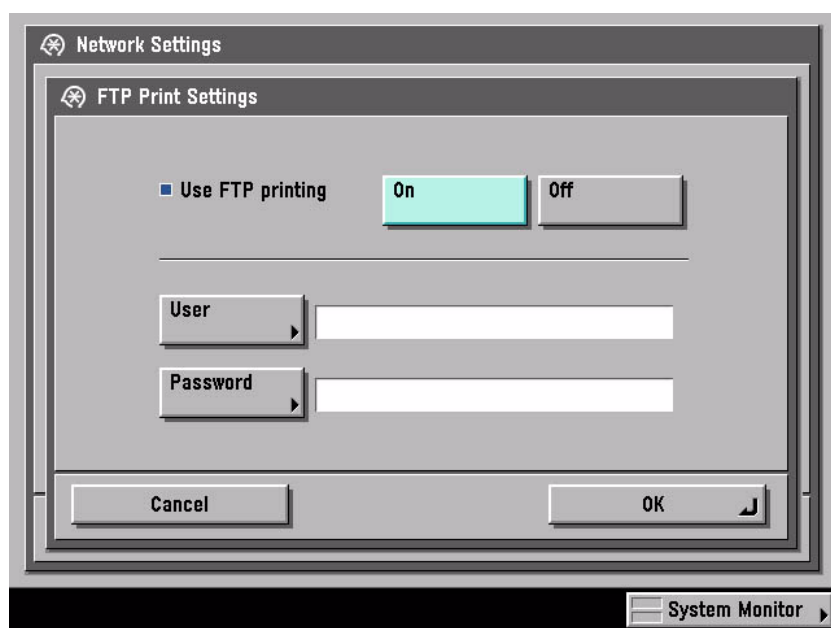

F-2-1

## Commands

The FTP server complies with the RFC 959 -- File Transfer Protocol -- but provides only printing function. Thus the server does not support other functions required as a RFC 959 compliant server. The commands available for the FTP client are "user," "password," "bin," "put," "bye," "hash," and "help." There is no use of other commands since the server does not provide functions other than printing. The following lists the notes to use the commands.

- To send print data with the command "put," set the mode to the binary mode using the command "bin." In the ascii mode, the data cannot be sent with the command "put."

- If the user and password fields are blank, any user with any password can log in. If the user name "anonymous" is used, any character string can be entered as the password. The device displays the string in User field of Log screen.

- This function is featured mainly to print prn files output from PDL drivers. The device processes text files and the like as it receives data in LPR (and does not properly print depending on settings.) The device of PostScript-compatible model can print PDF files, compatible with PDF V1.3.

The following shows a command specification example, which you will connect the device of the IP address "172.16.181.131" in FTP with the user name "test" and the password "test" and print the file "test.prn" in the root directory of the drive C on the client PC.

```
C:\>ftp 172.16.181.131
Connected to 172.16.181.131.
220 Connection established.
User (172.16.181.131:(none)): test
```

```
331 Password required to login.  
Password:      Note: The password is not displayed.  
230 User test logged in.  
ftp> bin  
200 Type set to IMAGE (binary).  
ftp> put c:\test.prn  
200 PORT command successful.  
150 Opened BINARY data connection for file transfe  
226 Transfer complete.  
ftp: 15871 bytes sent in 0.00Seconds 15871000.00Kb  
ftp> bye  
221 Server closing down connection.
```

C:\>

### Number of Connections and Used Ports

The maximum number of concurrent connections is three. If a user attempts to connect to the FTP server with which three connections have been established, the user cannot log in and fails in connection. The default port for the FTP server is 21. There is no measure provided to change the port.

The control port time-out is set to 300 seconds. You need to re-connect to the server if you have left the connection for 300 seconds or more after logging in. The data port time-out is 60 minutes. If a data transmission takes more than 60 minutes, the connection is automatically disconnected.

## 2.1.3 Halftone Settings

0008-5390

### Halftone Settings (PS B&W printers)



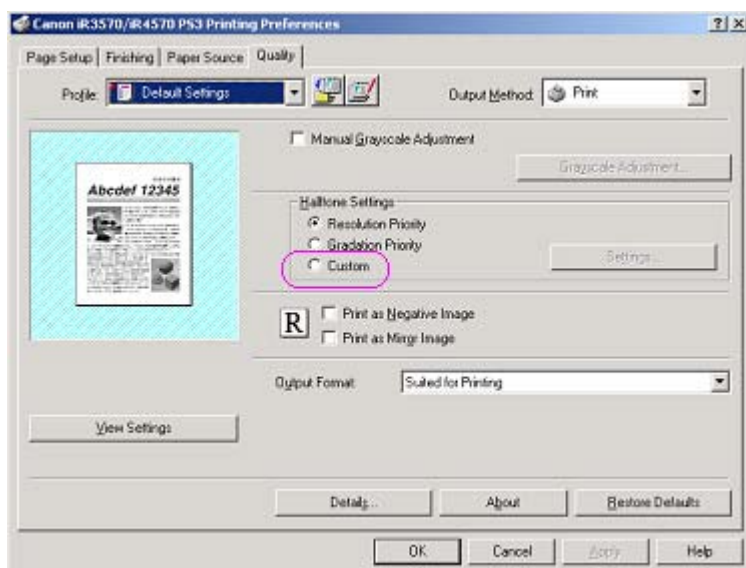

F-2-2

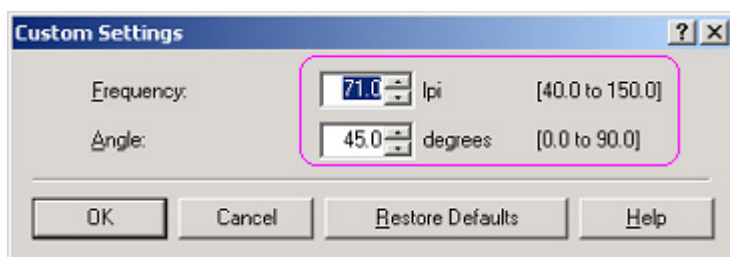

F-2-3

Only for monochrome PS printers, it will be possible to specify the halftone screen frequency and angle. For that, in the “Halftone Settings” section in the “Quality” tab, the “Custom” radio button and the “Settings” button will be provided.

The “Settings” button will be disabled by default and will be enabled by selecting the “Custom” radio button. Clicking the “Settings” button will open the “Custom Settings” dialog to set the halftone screen frequency and angle. The “Frequency” spin box will default to a value of 71.0 and will accept a value between 40.0 and 150.0. The “Angle” spin box will default to a value of 45.0 and will accept a value between 0.0 and 90.0.

## 2.1.4 Secured Print Jobs

0008-5624

### Overview:

Secured Print is the function that a password is provided to the PDL(UFR II and PCL) print job and it is sent to the device. Then, it is rasterized on the device side, saved in the image server and output by entering the password from the device’s panel. This function is used when dealing with the documents which you do not want other people to see, such as confidential documents.

#### a) Password is provided.

In order to conduct the Secured Print, the printer driver requires the user to enter the password from GUI. This password is provided to the print job and it is sent to the device. This function can be conducted by using CPCA protocol(UFR II and PCL).

**b) Job execution and pending**

PDL print job sent to the device as the Secured Print job is compiled on the job queue like the normal PDL print job. Then, it is rasterized by PDL interpreter, saved in the image server as the document image file and becomes pending here. However, all job information, such as paper supply/output, the number of copies and finishing information remains.

**c) Job started by entering the password**

If the Secured Print job is pending, the display indicating the pending state appears on the job status screen of the panel. If you select this job from the panel, you are required to enter the password. When the password you entered is same as the password provided from the printer driver, the pending job will be started. When the password is different, the job is treated as an error, so it is not started and it remains in the pending state. Entering the password to start the job cannot be executed before the Secured Print job transfers to the pending state.

**d) Output**

The started Secured Print job is output to the printer engine with the top priority. This top priority means that if the jobs can be changed in priority order, the Secured Print job can be prioritized. This job is proceeded according to all job information specified by the printer driver, etc., such as paper supply/output, the number of copies and finishing information. When the processing is completed and all documents are output, the documents and job information stored in the image server are deleted.

**e) Operations for Secured Print jobs**

Like other print jobs, Secured Print jobs can be deleted, interrupted, restarted and promoted by operating from the status screen of the print job. Regarding these operations, the device side does not distinguish from operations of the normal PDL job. That is, the password entry is required only when the job is output. If you interrupt or restart the job during outputting, the password setting and matching are not conducted.

**f) Automatically delete of Secured Print Jobs**

When Secured Print Job is continuing being suspended for a long time, apparatus deletes a job automatically. There are options for automatic job deletion time -- 1, 2, 3, 6, 12, and 24 hours. With a view of security and memory usage, no option longer than 1 day is available. The elapsed time starts after all the processes for the PDL data and the rendering for all the image data, for which Secured Print is specified, are finished.

**g) Specifications and Limitations on Secured Print Jobs**

The limitations on Secured Print jobs are listed as follows.

- Once data of a Secured Print job is printed, it is immediately deleted and cannot be printed any more.
  
- If the power for the controller is shut down, unprinted data of a Secured Print job is deleted from the printer.

- All the job information, represented by the paper source and output information, information of the number of copies, and finishing information, cannot be changed on the printer.
- If the entire raster information for a Secured Print job cannot be stored in the image server (hard disk drive) due to insufficient memory, the job results in an error, to be deleted.
- Up to 50 Secured Print jobs of image data being rendered and left unprinted can be stored.

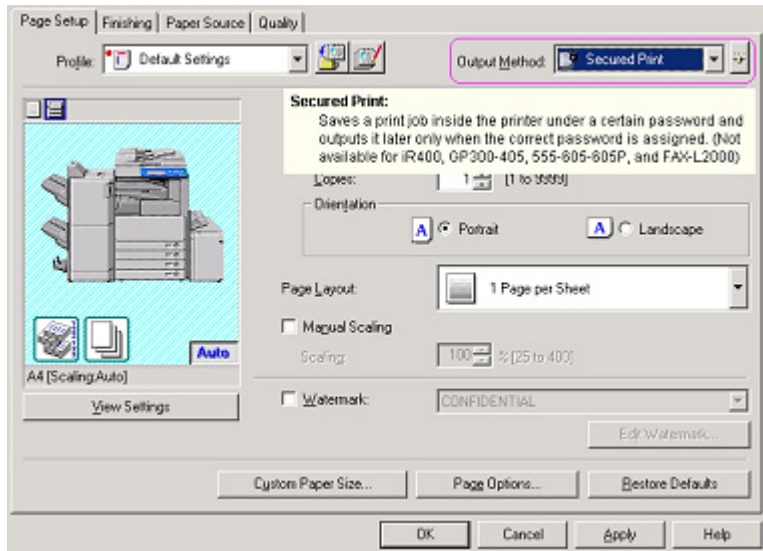

F-2-4

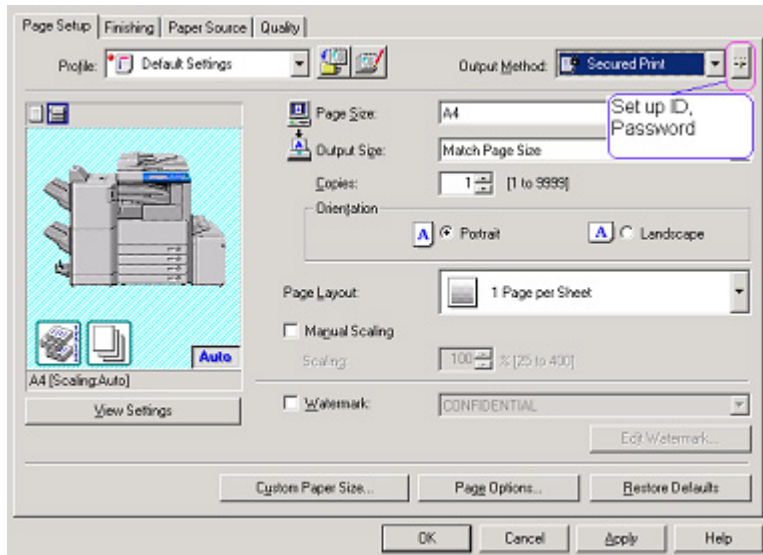

F-2-5

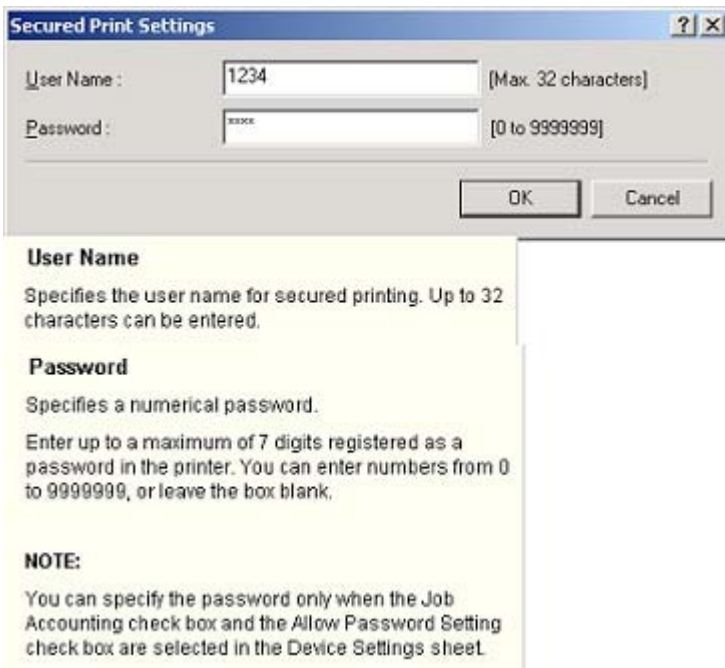

F-2-6

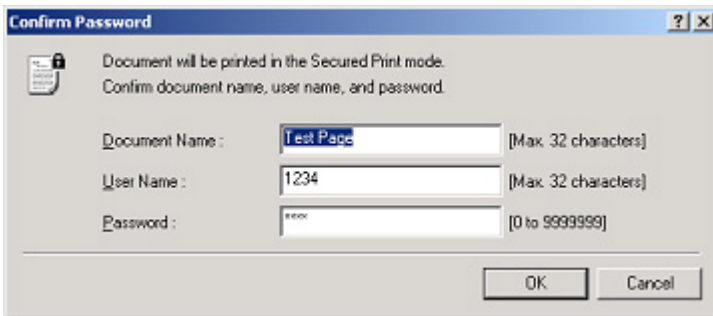

F-2-7

### 2.1.5 Up to 50 mm of Gutter

0008-5626

Up to 50 mm of the gutter can be specified. The gutter can be adjusted within a range from -50 mm to 50 mm in 1 mm increments. The local UI and the print driver have the controls for the gutter settings.

The image is shifted to the width value specified for gutter, making a margin. If the shift causes the image to overflow from the printable area, the overflowing area is missing from the print results. The overflowing image will not be reduced to fit into the printable area.

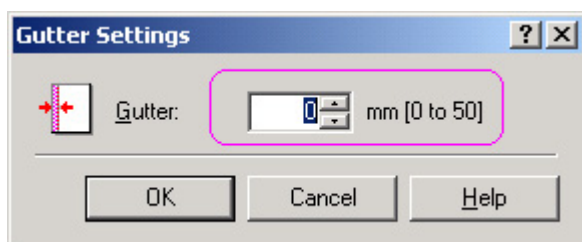

F-2-8

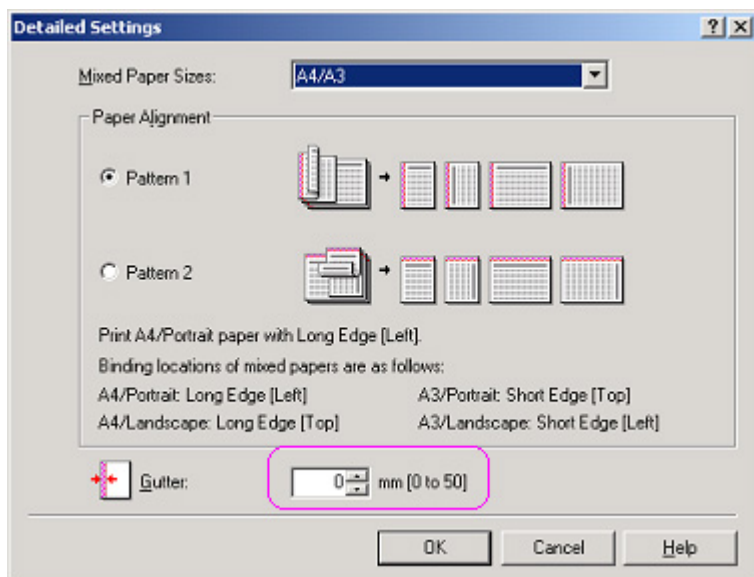

F-2-9

The gutter width range changed to 0-50 mm.

US: 0.0 to 2.0 inches

UK: 0.0 to 50.0 mm

## 2.1.6 Processing on System

0008-5622

### Processing after Power Shutdown

If the power is shut down during PDL data processing, all the image data temporarily stored in the hard disk drive to be printed or stored in Mail Boxes are destroyed and the jobs are canceled. PDL data stored in the hard disk drive immediately before a power shutdown are destroyed as the power is shut down. Processing the data of those, therefore, will not resume when the power is turned on after the shutdown. Jobs interrupted by a power shutdown will be displayed in the Log list with the End Code “NG (#852).”



---

# Chapter 3    Installation

---





# Contents

3.1 Checking components .....	3-1
3.1.1 Checking the Contents.....	3-1
3.2 Installation procedure .....	3-2
3.2.1 Installation .....	3-2



## 3.1 Checking components

### 3.1.1 Checking the Contents

0008-2712

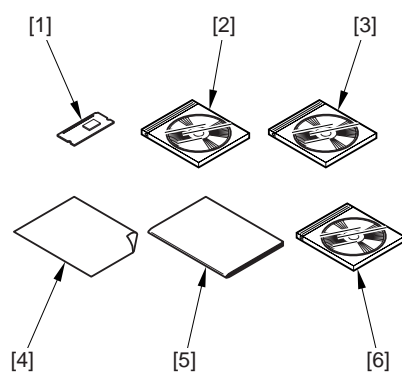

F-3-1

T-3-1

[1]	Boot ROM (N type)	1 pc.
[2]	User software CD-ROM unit	1 pc.
[3]	N/W ScanGear CD-ROM	1 pc.
[4]	Release note	1 pc.
[5]	N/W Quick Start Guide	1 pc.
[6]	User Manual CD-ROM	1 pc.

---

## 3.2 Installation procedure

---

### 3.2.1 Installation

0008-2722

#### 1. Turning Off the Host Machine

---



Be sure to go through the following steps on the host machine before starting the work

1. Hold down the control panel power switch for 3 sec or more.
  2. Go through the shutdown sequence as instructed on the screen so that you may turn off the main power switch.
  3. Turn off the main power switch.
  4. Disconnect the power cable (from the wall outlet).
- 

#### 2. Installation

- 1) Remove the rear cover.
- 2) Remove the 4 screws [1], and detach the main controller box cover [2].

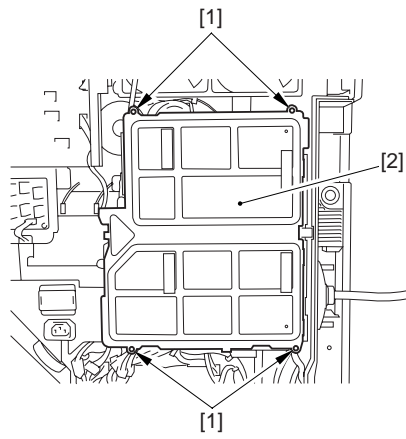

F-3-2

- 3) Shift the release lever [1] in the direction of the arrow to release and detach the boot ROM [2].

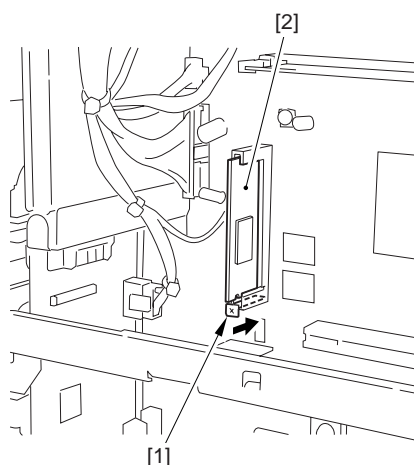

F-3-3

4) Mount the boot ROM [1] that comes with the product.

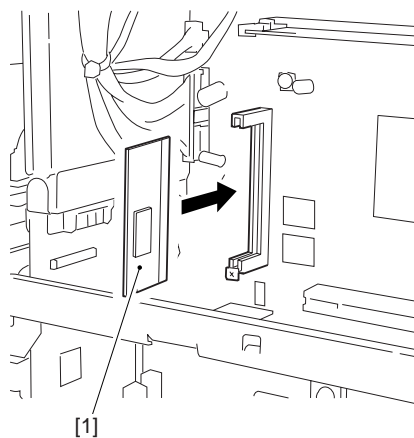

F-3-4

- 5) Attach the main controller box cover.
- 6) Attach the rear cover.
- 7) Connect the host machine's power cable (to the power outlet).
- 8) Turn on the main power switch.

### 3. Checking the Installation

Make the following selections, and check the state of the following bits: COPIER > ACC-STS > PDL-FNC1.

111x xxxx xxxx xxxx (0: OFF; 1: ON)

In the case of the PDL-FNC1, bits 31 through bits 16 are indicated.

Be sure that the following bits are '1': 31, 30, 29.



Jan 5 2005

**Canon**